



UNIVERSITÀ
DEGLI STUDI
DI BERGAMO

Dipartimento
di Ingegneria Gestionale,
dell'Informazione e della Produzione

ICT/Electronic Lab Kick-off meeting

23th February 2026

Agenda

- Welcome to the EMH Lab
- Introduction about the ICT/Electronic Lab
- Projects Presentations
- Q&A



Professors of the modules

- DATA ANALYSIS LAB

- Professor: [Antonio FERRAMOSCA](#)
- Contact: antonio.ferramosca@unibg.it

- SENSING DEVICES LAB

- Professor: [Elisa RICEPUTI](#)
- Contact: elisa.riceputi@unibg.it

- VIRTUAL REALITY LAB

- Professor: [Andrea VITALI](#)
- Contact: andrea.vitali1@unibg.it



How to choose the projects?

- After the presentation of the projects:
 - Cover letter (We will share with you a word file)
 - Letters of interest/Cover letters for **2 projects**
 - List of group members: a student must be elected as group coordinator
 - Motivations of your choice for a specific project
- The group coordinator will **send an e-mail with all the requested information** to the *coordinator and to the project coordinator of each chosen project.*
- Deadline for letters of interest: **3th March 2026**
- The professors will give you the final assignment of the project according to the letters of motivation



Lessons, Tutorials, Meetings and Final Exam

- The lab has own e-learning course
 - [Web Link to the Moodle Course](#)
 - Course Name: **ICT - ELECTRONIC LAB - 175010 - 2025-26**
- The general-purpose lessons will be available the official calendar on the UniBG web-site
- Each professor could schedule a list of meetings of own course to share lessons/tutorial for his/her specific thematic area
- Each specific group may ask further meetings with a project coordinator or a professor
- All the information about the final exam will be available by a PDF file shared with you at the end of this introduction. For each specific question you feel free to ask at your project coordinator.



The access to the Laboratory and the Tutors

- It will be possible to access to the EMH Laboratory at the Point Building
- If it needed, specific information will be sent to the group coordinator about **how to enter in the building** of the laboratory
- **Tutors** will follow you during the design/development of the projects



Projects for ICT/Electronic Lab...



UNIVERSITÀ
DEGLI STUDI
DI BERGAMO

Dipartimento
di Ingegneria Gestionale,
dell'Informazione e della Produzione

Project 1

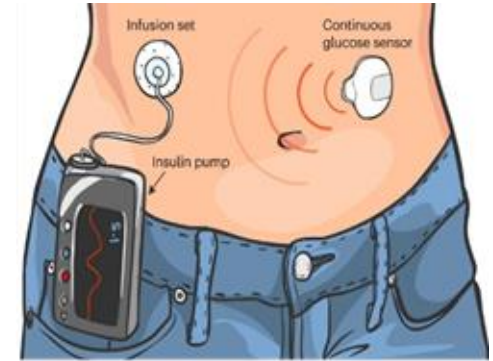
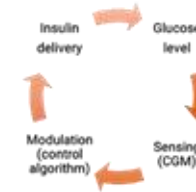

Generation of Syntehtic Data for Type 1 Diabetes Data Set Augmentation Using AI

TUTOR:
Prof. Antonio Ferramosca

**Number of
students in the
group:**

4



UNIVERSITÀ
DEGLI STUDI
DI BERGAMO

Dipartimento
di Ingegneria Gestionale,
dell'Informazione e della Produzione

Artificial Pancreas is a closed-loop system for automatic blood glucose control in T1D subjects. Made of 3 parts that work in sync to mimic how a healthy pancreas controls blood glucose.

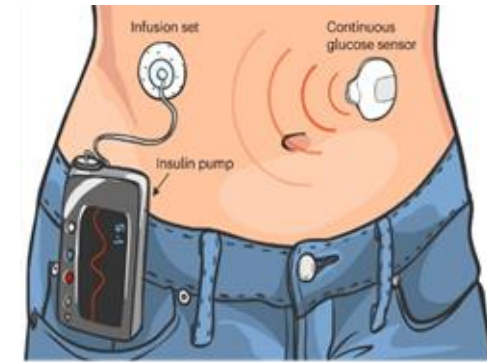
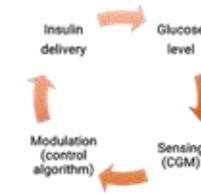

Artificial pancreas **requires data** from multiple sources for accurate insulin dose estimation such as continuous glucose sensors, past insulin dosage information, meal quantity and time and physical activity data

Most of the data collected are **not freely available** and tend to be heterogeneous due to the variety of factors and scenarios that affect T1DM patients.

The goal of the project is to **use AI tools to generate synthetic data sets** with the intention of augmenting continuous glucose monitor data from individual patients.

These synthetic data can be used with the aim of improving the overall performance of prediction models based on machine learning techniques.



What to do

Goal: use AI tools to generate synthetic data sets with the intention of augmenting continuous glucose monitor data from individual patients.

You will work on data from 30 virtual patients (10 child, 10 adolescents, 10 adults) from the UVA/Padova metabolic simulator.

What should you do?

1. Collect data from UVA/Padova simulator (30 virtual patients).
2. Analyze and understand data and system's physiology.
3. Build an AI tool for the generation of synthetic data to enlarge the virtual population.



Project 2

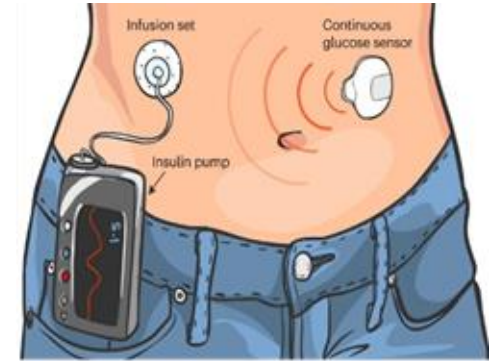
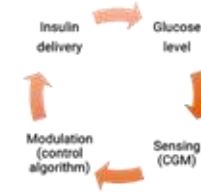

Hyper- and Hypo- glycemia allarm detection using AI

TUTOR:
Prof. Antonio Ferramosca

**Number of
students in the
group:**

4



UNIVERSITÀ
DEGLI STUDI
DI BERGAMO

Dipartimento
di Ingegneria Gestionale,
dell'Informazione e della Produzione

Artificial Pancreas is a closed-loop system for automatic blood glucose control in T1D subjects. Made of 3 parts that work in sync to mimic how a healthy pancreas controls blood glucose.

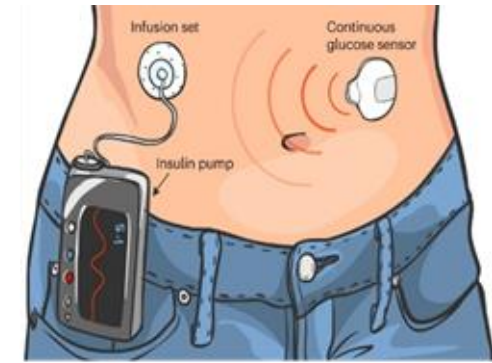
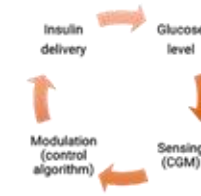

Therapies aim at maintaining blood glucose levels within **Normal Glycemic range**: blood glucose levels between 70 mg/dl and 140 mg/dL.

T1 diabetic patients are subject to high fluctuations in their blood-glucose levels due to various causes such as: bad carbs counting, errors in insulin infusions computations, physical activity, stress, etc.

Hypoglycemia's symptoms can range from mild to severe if untreated, and eventually lead to death.

Hyperglycaemia's effects are seen over the long term

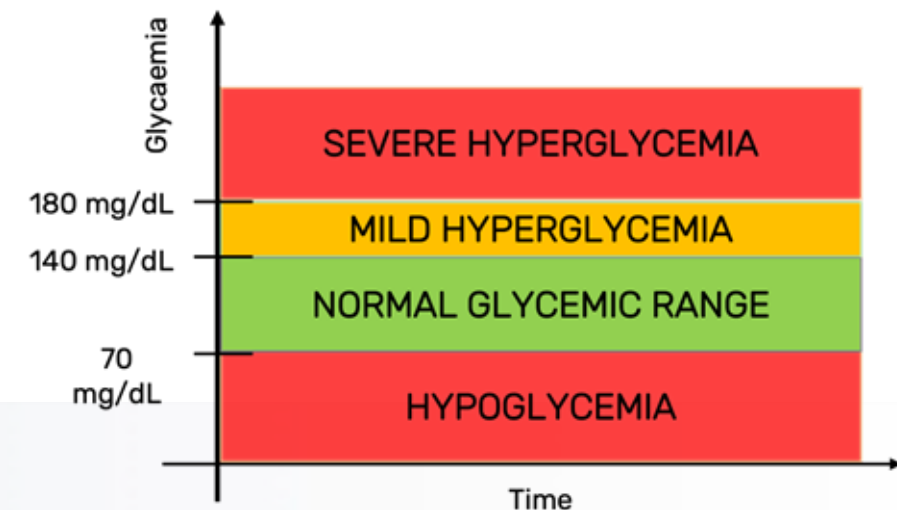

What to do

Goal: use AI tools to generate predictive alarms for hypo- and sever hyper-glycemia events.

You will work on data from 30 virtual patients (10 child, 10 adolescents, 10 adults) from the UVA/Padova metabolic simulator.

What should you do?

1. Collect data from UVA/Padova simulator (30 virtual patients).
2. Analyze and understand data and system's physiology.
3. Build an AI tool for the generation of alarms for hypo- and hyper- glycemia events 30/60 minutes before the events.



Project 3

Feasibility Study on the Use of Force-Sensitive Resistor Sensors for Biomedical Applications

COORDINATOR:

Prof.ssa Elisa Riceputi

TUTOR:

Eng. Matteo Verzeroli

Number of
students in the
group:

4



UNIVERSITÀ
DEGLI STUDI
DI BERGAMO

Dipartimento
di Ingegneria Gestionale,
dell'Informazione e della Produzione

Disclaimer!!

*The following slides contain images of surgeries and/or body parts.
If you're sensitive to these types of images, I recommend looking away for a
few minutes.*



Background

- One type of brain surgery involves going through the orbit → the skull is left untouched!!



Visibility for the surgeon

- In order to make space for the surgeon to operate, it is necessary to **gently** move the eyeball aside
- Metal **flat sticks** are used to move the eyeball by hand (the sticks are deformed by hand in the most suitable way from patient to patient)
- The **visibility** for the surgeon is **significantly reduced** by the presence of the assistant that is holding the sticks still in place

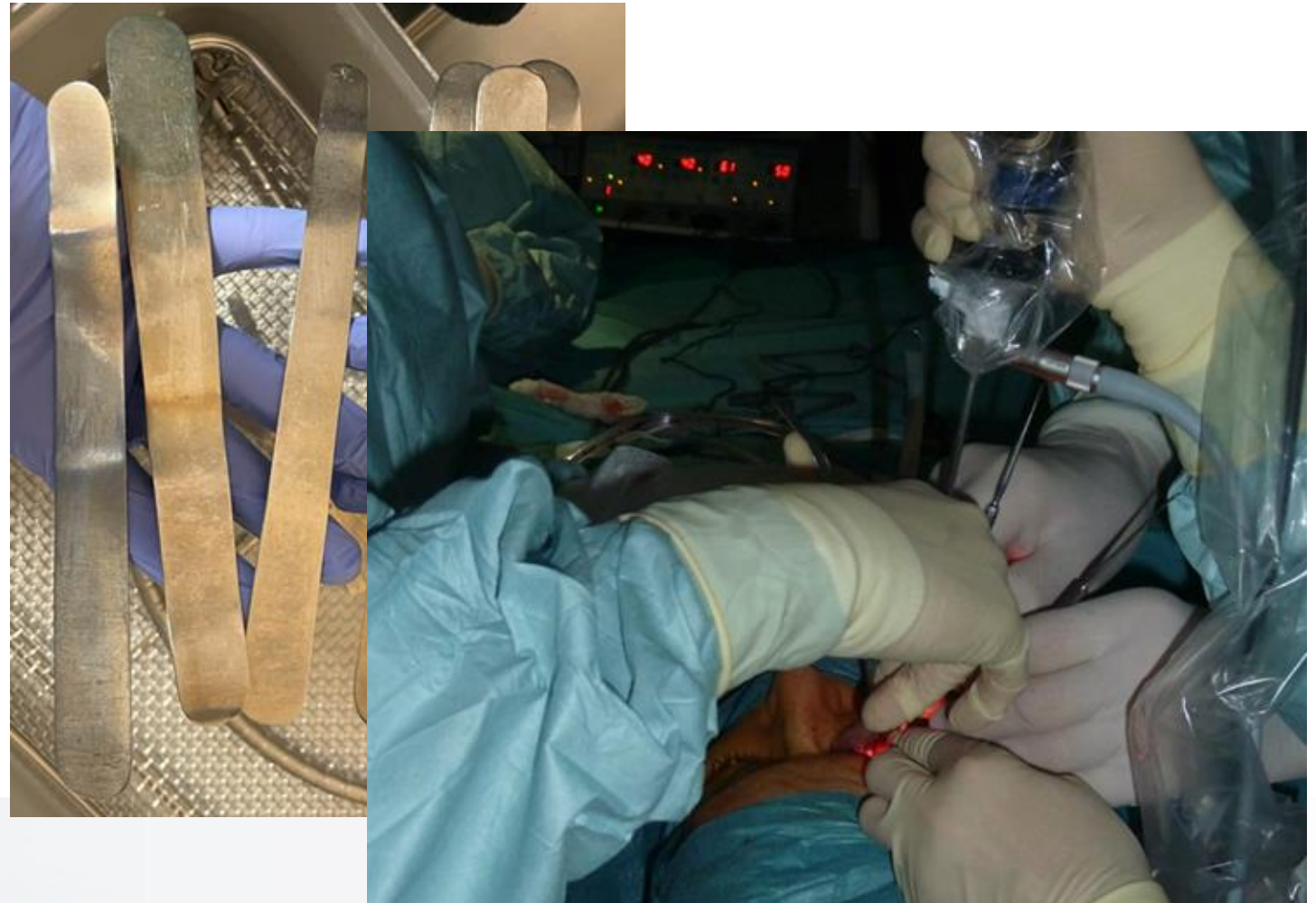

Possible solution?

- Developing an ad-hoc mechanical retractor
- Possibility to fix the angle (thus the opening)
- Edge sensible to the *pressure (force)* exerted on the eyeball
 - Two **pressure (force) sensors** are needed!!

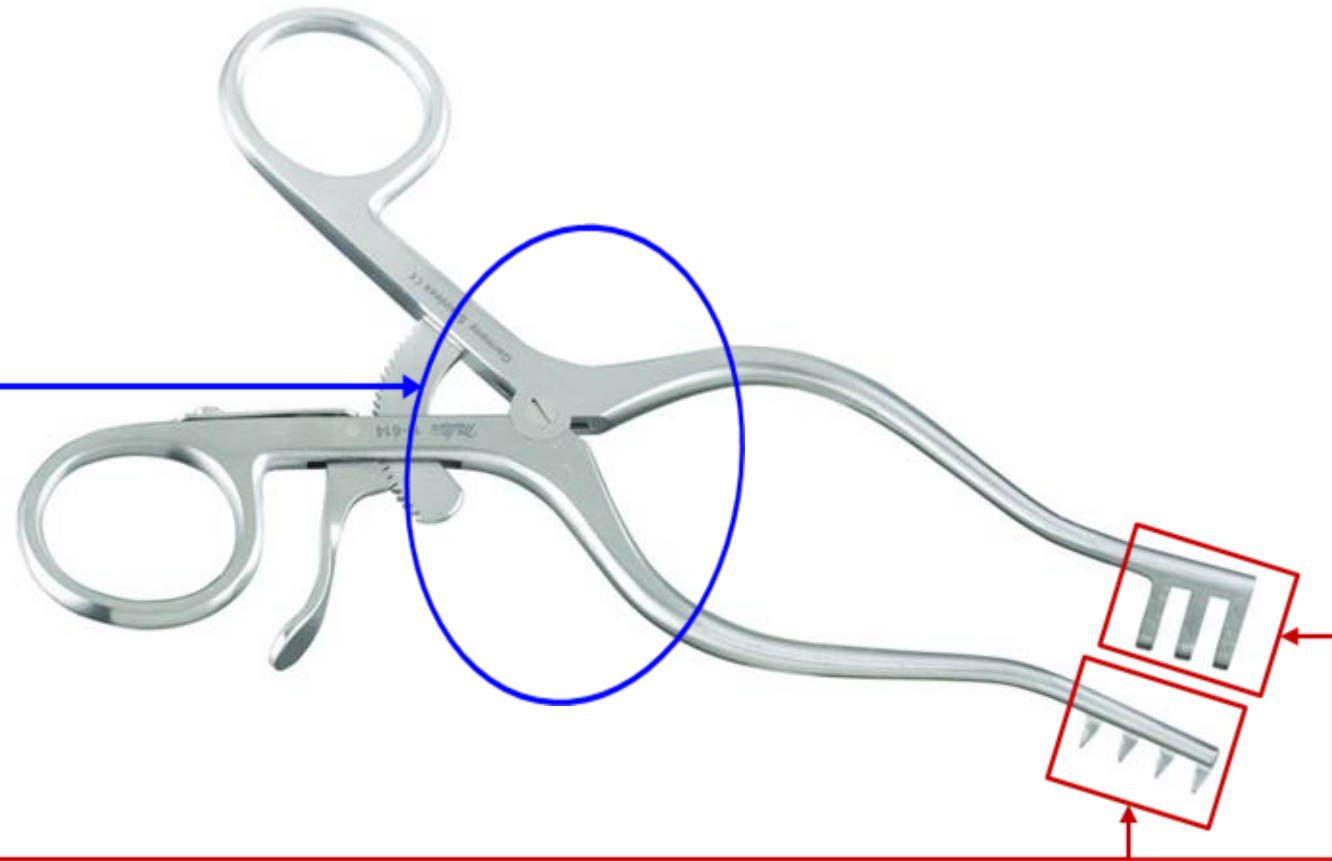

Project proposal

- Feasibility study for the development of a **portable** system acting as an ad-hoc mechanical retractor using **force sensors**:
 - Physical **dimension**
 - Range of **expected measurements**
 - Try all the sensors in a condition as similar as possible of the operating condition
 - Mount different sensors on the sticks and try all of them on a corpse in order to see which one is more sensible (gives the best signal to noise ratio)
- Other potential applications?
 - Hand movements
 - Posture monitoring
 - Ideas??

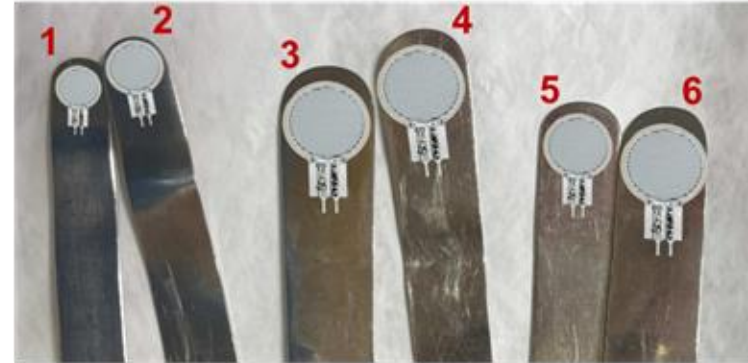

What should you do?

- Developing firmware for evaluation boards of different force sensors
- Developing an ad-hoc electronics for the optimization of acquired data in terms of signal to noise ratio (S/N ratio)
- Validate acquired data and robustness of the system

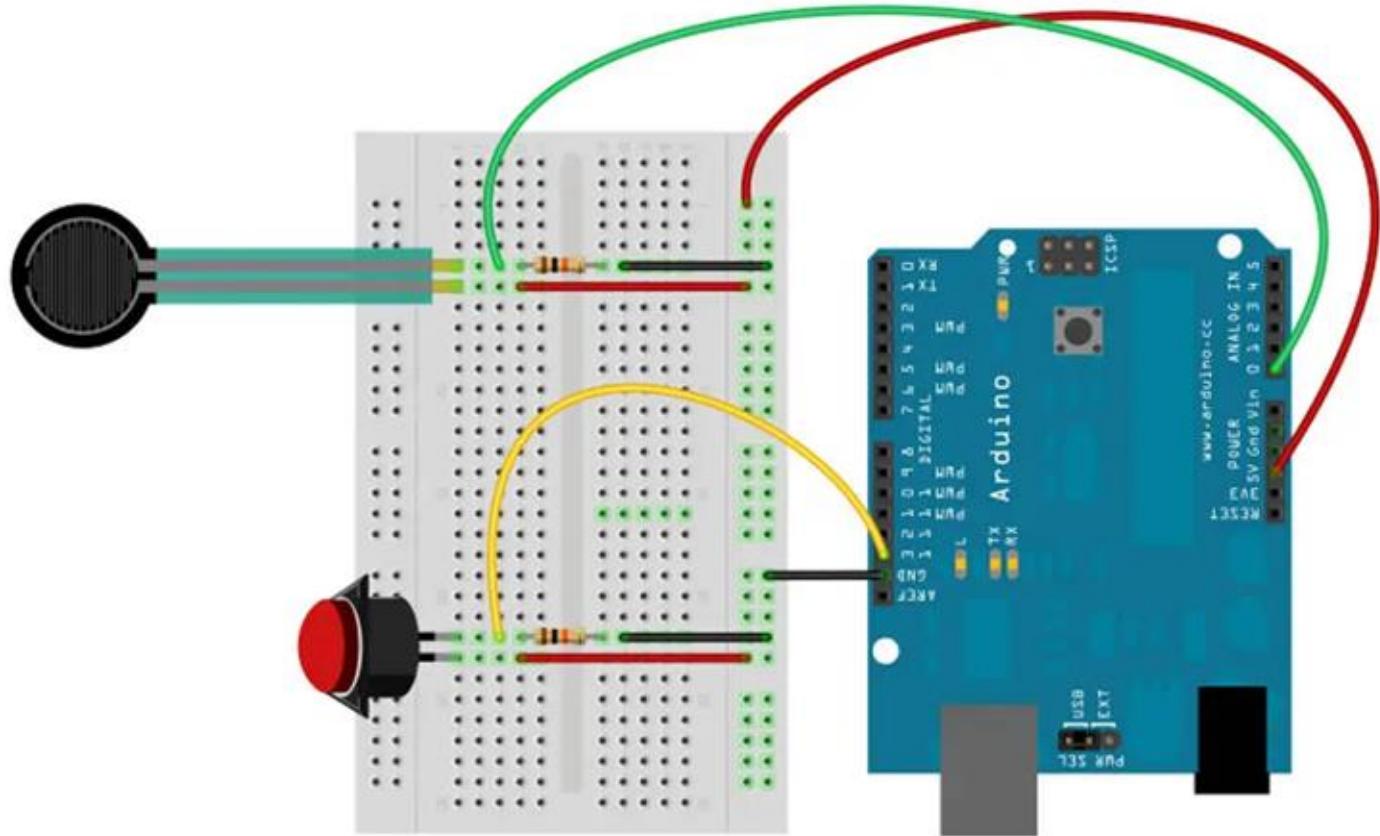

Project 4

Development a of low cost control system for laser scanning imaging applications

COORDINATOR:

Prof.ssa Elisa Riceputi, Prof. Paolo Pozzi

TUTOR:

Eng. Matteo Verzeroli

**Number of
students in the
group:**

4



**UNIVERSITÀ
DEGLI STUDI
DI BERGAMO**

Dipartimento
di Ingegneria Gestionale,
dell'Informazione e della Produzione

Confocal Microscopy

- Traditional microscopes create **imperfect** images of 3D samples due to **out-of-focus light**
- The gold standard for 3D imaging in biology is laser scanning confocal microscopy
- Commercial confocal microscopes are **prohibitively expensive** for researchers in developing countries, and for teaching activities
- An **open-source, low budget** confocal microscope can be built, but it requires **custom electronics**

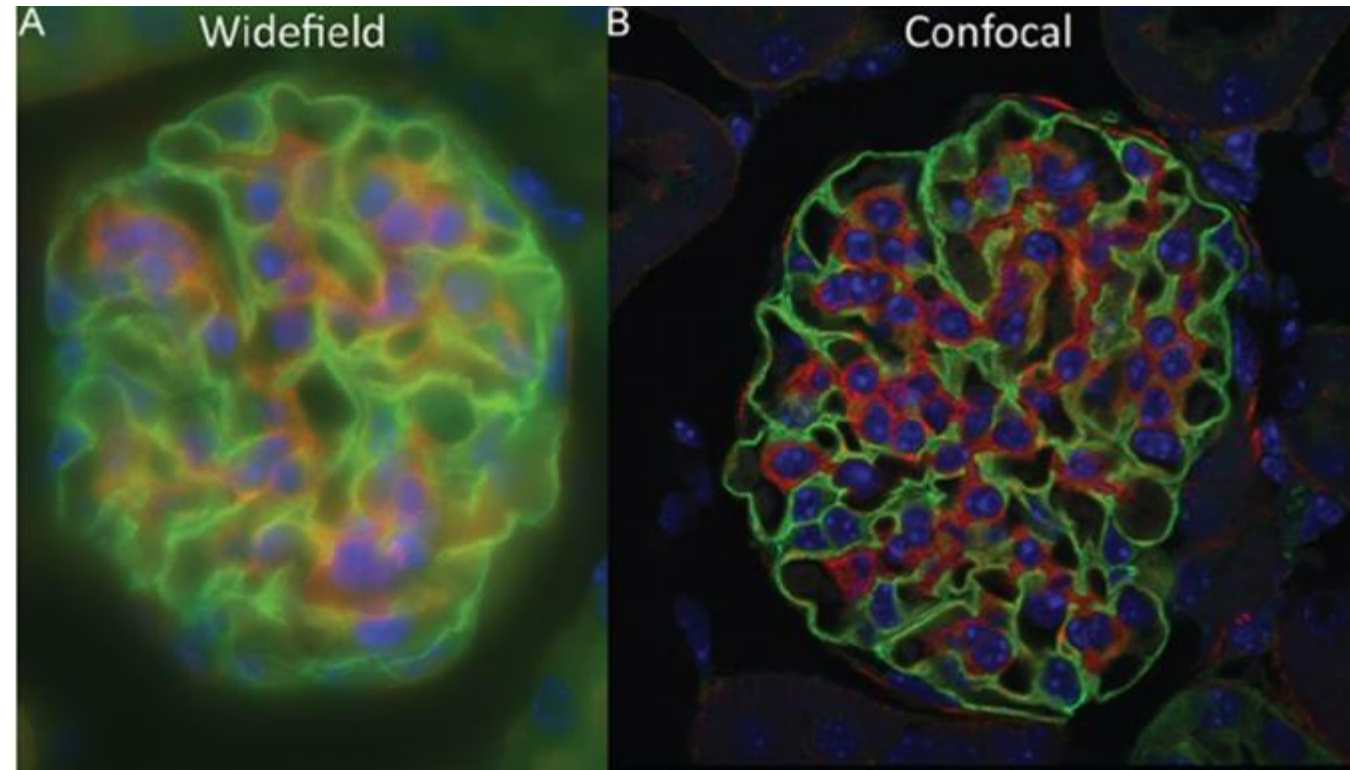

Sample image from “Jonkman J et Al. Any Way You Slice It-A Comparison of Confocal Microscopy Techniques. J Biomol Tech. 2015”

Background

- A confocal microscope **scans** the **sample volume** one “**voxel**” at a time with a focused laser
- Fluorescence or scattered **light** from the sample **travels back** through the scanner, the focus of the laser is always imaged on the same point
- A **pin-hole** aperture blocks all out-of-focus light, a **detector records light** from the voxel
- **Precise synchronization** is needed to drive the scanning mirrors and record the detector signal

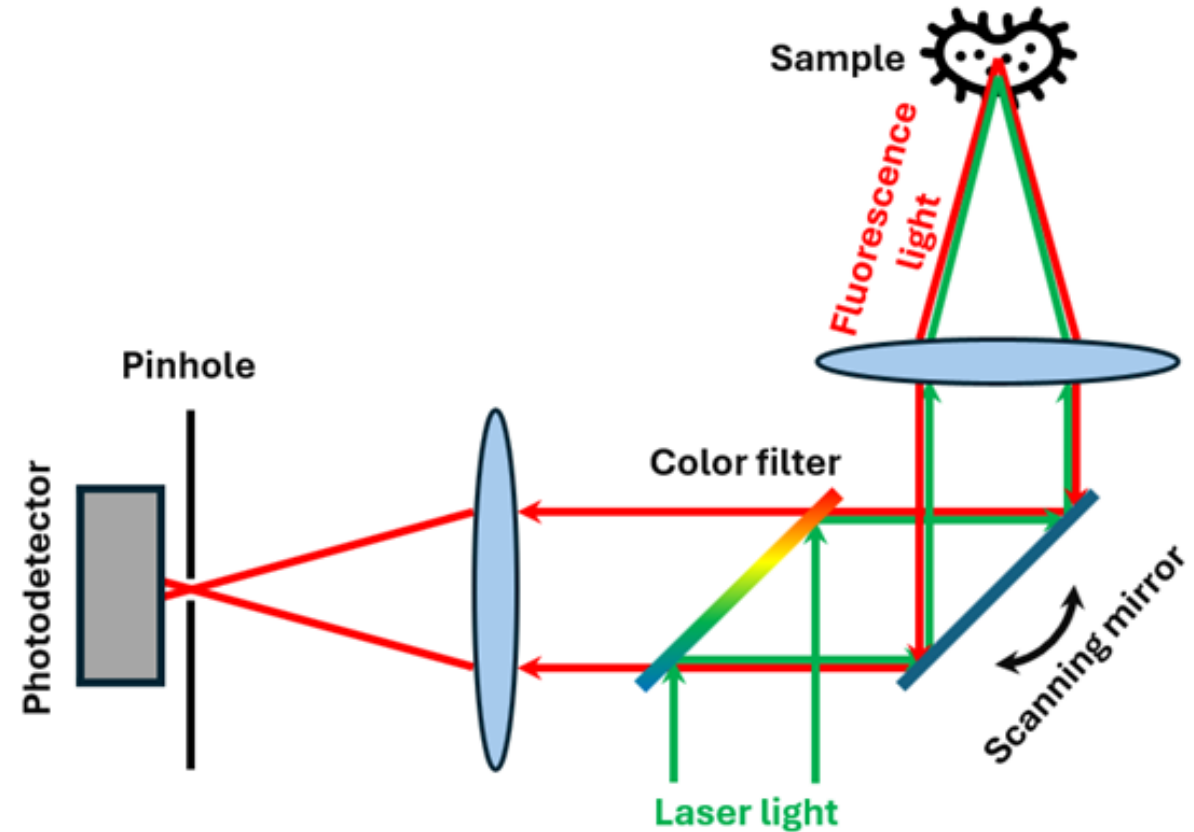

Project proposal

- Develop a *customized* low-cost system for controlling the movements of the two scanning mirrors
 - **Two control lines** are needed (sawtooth waves with same amplitude, different frequencies)
 - A **third line to read the output** of the laser interaction (photodiode + amplification circuitry)

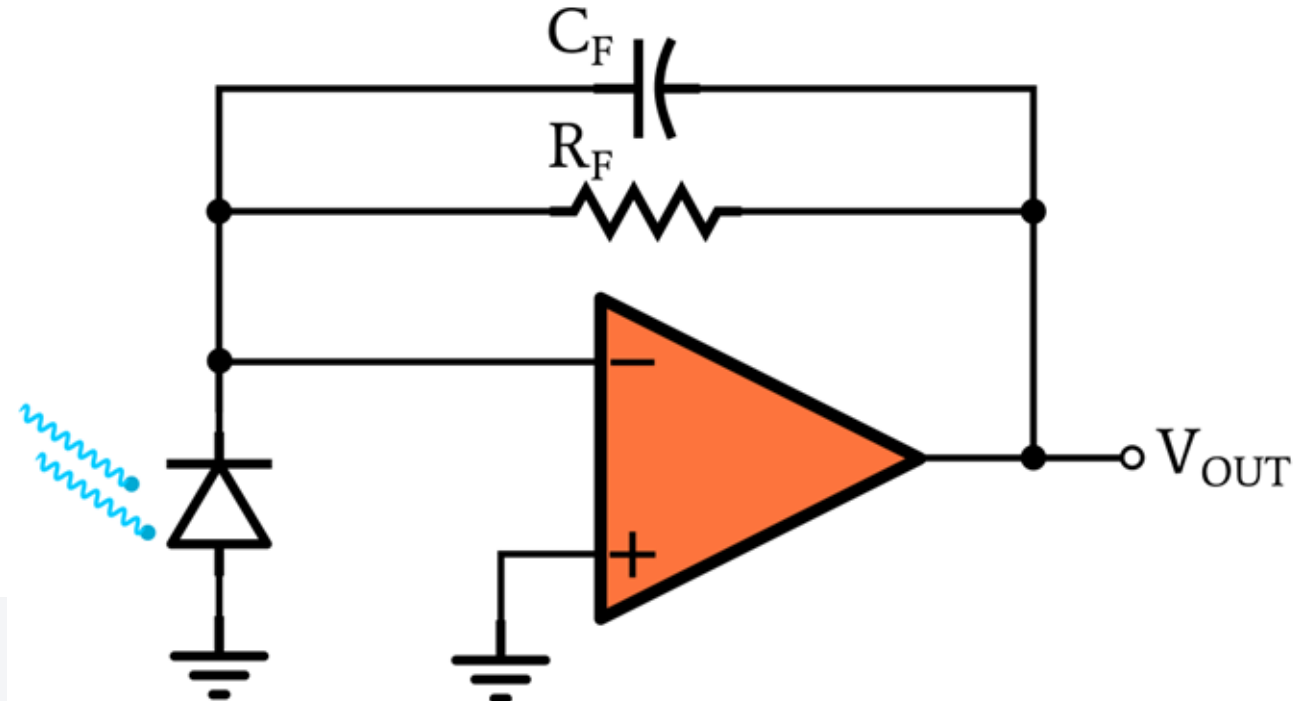
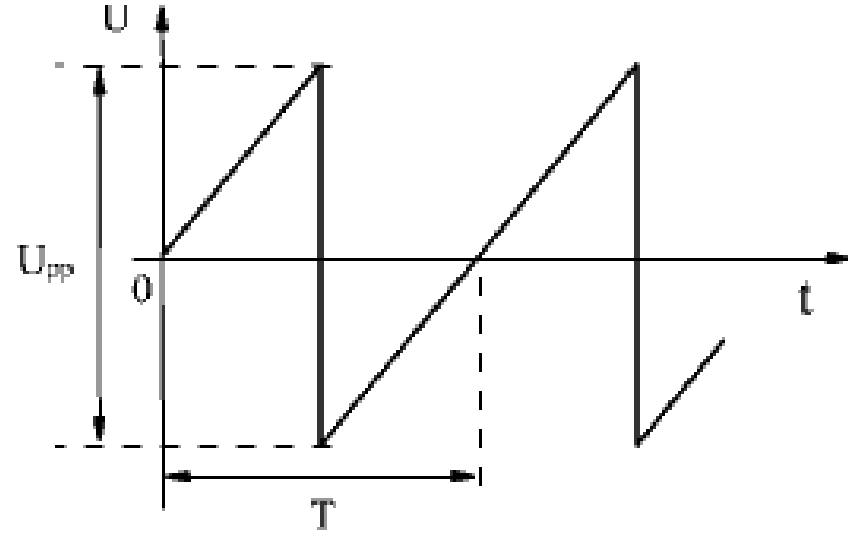

What should you do?

- Study an electronic circuit able to provide to the scanning mirrors the control signals and, simultaneously, reading the output of the laser
 - prototype with breadboard
 - final project with Fusion (Eagle) software
- Developing Arduino firmware

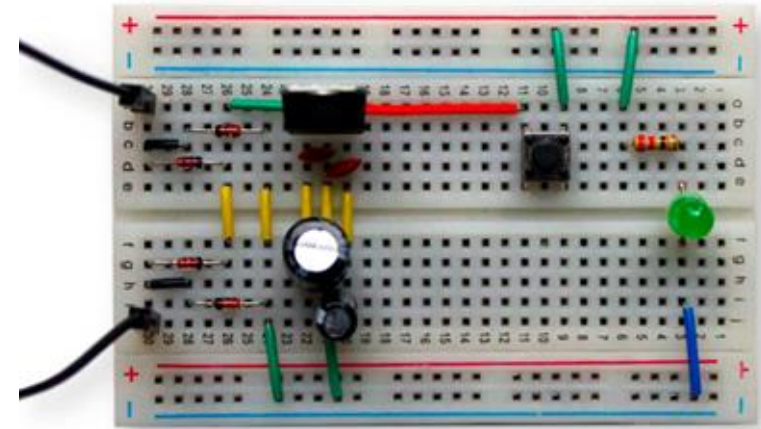

JEDRSIAK

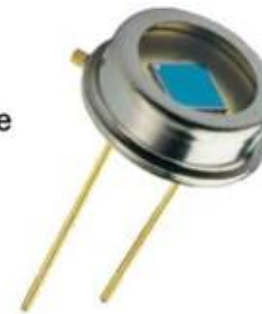
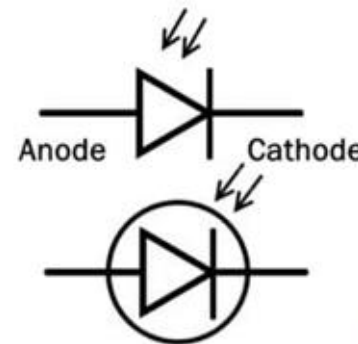

PhotoDiode

Project 5

eXtended Reality in occupational medicine: Augmented Reality and Motion Capture for Ergonomics

TUTOR:

Prof. Andrea Vitali

Tutors: Davide Ferrari, Gloria Moro

**Number of
students in the
group:**

4



**UNIVERSITÀ
DEGLI STUDI
DI BERGAMO**

Dipartimento
di Ingegneria Gestionale,
dell'Informazione e della Produzione

Email: Davide.Ferrari@unibg.it Gloria.Moro@unibg.it

Context: Challenges in Physical Ergonomics

What is Physical Ergonomics?

- Focuses on designing workplaces and tasks to fit human capabilities.
- Aims to prevent musculoskeletal disorders and improve efficiency.

Current Limitations in Ergonomic Assessments

- **Traditional methods:** Observational analysis by ergonomists.
- **Challenges:** Subjectivity, time-consuming, lack of real-time feedback.

The Need for Innovation

- **Emerging technologies** like Augmented Reality (AR) and motion capture can enhance accuracy and efficiency.
- **Introducing AR4Ergo:** A real-time AR-based tool to improve ergonomic assessments.



Aim of the project

Goal:

-  Implement Muscular Activation Simulation and Visualization

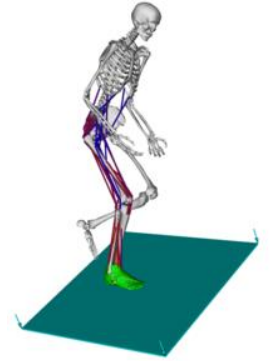

Why?

- Current Capabilities: AR4Ergo computes **ERGONOMIC INDEXES** in real time using **Xsens** motion capture.
- Needed Expansion:
 - Add a module for simulating muscular activation.

Student Task:

- Development of an automated pipeline from motion acquisition to kinetic simulation of muscular activation.
- Ensure seamless data flow between motion capture, OpenSim simulation and AR visualization.



Methods and Tools

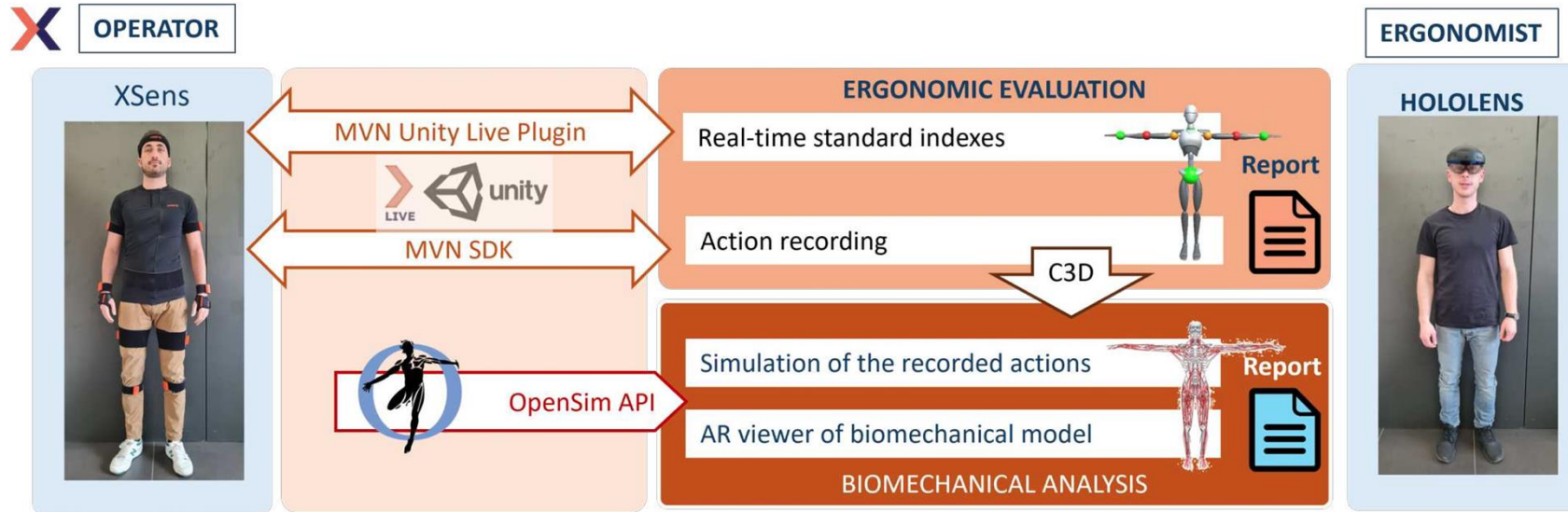

SETUP



MOTION CAPTURE

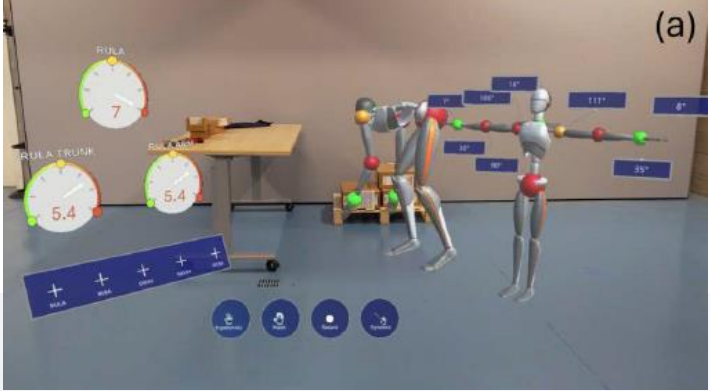

KINETIC Simulation/Visualization

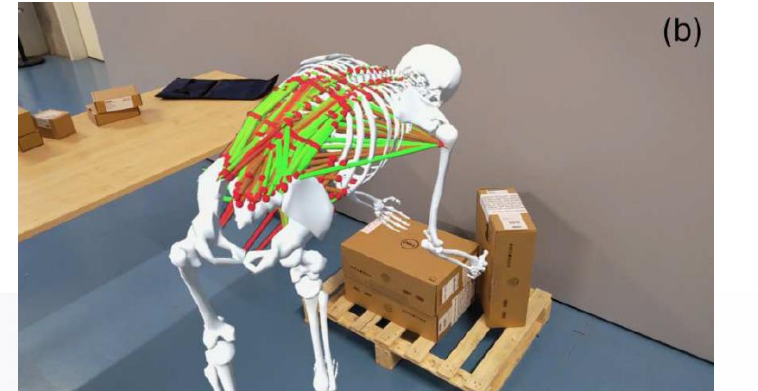

Project 6

A feasibility analysis of tremor acquisition in patients with Parkinson's disease

TUTOR:

Prof. Andrea Vitali, Prof.ssa Elisa Riceputi

Tutors: Ivana Mostachetti, Matteo Verzeroli

**Number of
students in the
group:**

4



Context

- Patients with Parkinson's disease
- Upper limb and fine hand movements
- Serious Games in Rehabilitation
- Hand Motion Tracking
- Need of clinical assessment

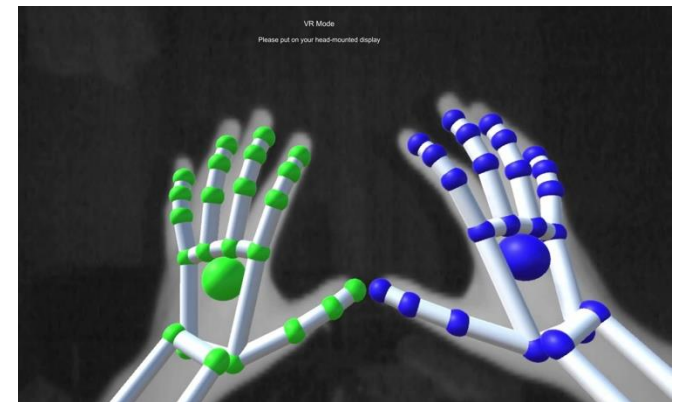

Hand tracking tools

Leap Motion Controller



Inertial Measurement Unit (IMU)

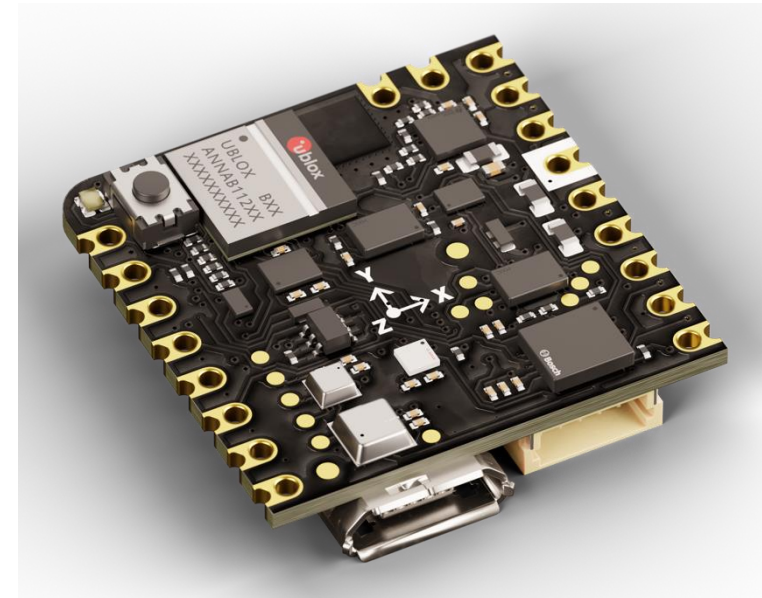

UNIVERSITÀ
DEGLI STUDI
DI BERGAMO

Dipartimento
di Ingegneria Gestionale,
dell'Informazione e della Produzione

Aim of the project

Is it possible to acquire tremors in Parkinson's disease while performing a Serious Game?

- Acquisition of **medical knowledge**.
- Development of a **serious game** using a Leap Motion Controller and an IMU device.
- **Analysis** of the resulting acquisition's **feasibility and robustness**.



Methods and Tools

- **Serious Game** development → **Unity, Leap Motion** and **IMU**



- **Results Analysis** → Matlab or Python

